

PARTS MANUAL

**ORDER PICKER
R30XMF3 (A169)
R30XMA3 (A185)
R30XM3 (H118)**

CUSTOMER EDITION

HYSTER

SECTIONS

1	FRAME
2	ELECTRICAL SYSTEM
3	DRIVE UNIT
4	STEERING SYSTEM
5	BRAKE/ACCELERATOR SYSTEM
6	LOAD WHEEL
7	HYDRAULIC SYSTEM
8	MAST-THREE STAGE FULL FREE-LIFT
9	OPTIONS
10	FIELD CONVERSION KITS
11	NUMERICAL INDEX

This Parts Manual is divided into 11 major sections which are listed above. Quick reference to these sections can be made by placing the right thumb on the tab of the desired section, bending the book back and thumbing the pages to the corresponding tab.

**Thanks very much for your reading,
Want to get more information,
Please click here, Then get the complete
manual**

JustClickHere 

NOTE:

**If there is no response to click on the link above,
please download the PDF document first, and then
click on it.**

**Have any questions please write to me:
admin@servicemanualperfect.com**

TABLE OF CONTENTS

DESCRIPTION	PAGE
B	
BATTERY STAND	9-18
BATTERY TRAY AND PULLER	
A169 (R30XMF3) A185 (R30XMA3) H118 (R30XM3)	9-8
BRAKE ASSEMBLY	
A169 (R30XMF3) A185 (R30XMA3) H118 (R30XM3)	5-2
C	
CASTER WHEEL	3-20
CHAINS, PINS, AND ANCHORS	
THREE STAGE - A169 (R30XMF3)	8-14
THREE STAGE - A185 (R30XMA3) H118 (R30XM3)	8-20
CHASSIS ELECTRICAL SYSTEM	
FURNITURE - A169 (R30XMF3)	2-4
WIRE HARNESSSES - A169 (R30XMF3) A185 (R30XMA3) H118 (R30XM3)	2-12
WITH TRACTION HOIST - A185 (R30XMA3) H118 (R30XM3)	2-8
CHASSIS TO PLATFORM WIRING	
A169 (R30XMF3) A185 (R30XMA3) H118 (R30XM3)	8-2
CONSOLE ELECTRICAL SYSTEM	
A169 (R30XMF3) A185 (R30XMA3) H118 (R30XM3)	2-14
COLD STORAGE - A185 (R30XMA3) H118 (R30XM3)	2-16
CONTACTOR PANEL	
24 VOLT "EE" - A169 (R30XMF3) A185 (R30XMA3) H118 (R30XM3)	2-22
24 VOLT STANDARD - A169 (R30XMF3) A185 (R30XMA3) H118 (R30XM3)	2-24
36 VOLT AC HOIST STANDARD - A169 (R30XMF3) A185 (R30XMA3) H118 (R30XM3)	2-21
36 VOLT EE AC HOIST - A169 (R30XMF3) A185 (R30XMA3) H118 (R30XM3)	2-20
36 VOLT EE DC HOIST - A169 (R30XMF3) A185 (R30XMA3) H118 (R30XM3)	2-25
36 VOLT LARGE CHASSIS STANDARD - A169 (R30XMF3) A185 (R30XMA3) H118 (R30XM3)	2-27
COVER ASSEMBLY	
CONSOLE - A169 (R30XMF3) A185 (R30XMA3) H118 (R30XM3)	1-24
COWL	
ADJUSTABLE - A169 (R30XMF3) A185 (R30XMA3) H118 (R30XM3)	1-2
FIXED - A169 (R30XMF3) A185 (R30XMA3) H118 (R30XM3)	1-4
D	
DECAL AND PLATE LOCATION	
A169 (R30XMF3)	1-6
A185 (R30XMA3) H118 (R30XM3)	1-8
E	
ELECTRICAL COMPONENTS	
A169 (R30XMF3) A185 (R30XMA3) H118 (R30XM3)	2-18
F	
FORKS	1-26
G	
GATE ASSEMBLY	
AUSTRALIAN MARKET	1-32

TABLE OF CONTENTS (continued)

DESCRIPTION	PAGE
GEAR BOX	
STEER MOTOR - A169 (R30XMF3) A185 (R30XMA3) H118 (R30XM3)	4-10
GUIDE ROLLER	
A169 (R30XMF3) A185 (R30XMA3) H118 (R30XM3)	9-10
GUIDE ROLLER KITS	
H	
HOODS AND COVERS	
A169 (R30XMF3)	1-10
A185 (R30XMA3) H118 (R30XM3)	1-12
HYDRAULIC CONTACTOR	
24 VOLT HOIST - A169 (R30XMF3) A185 (R30XMA3) H118 (R30XM3)	2-28
36 VOLT - A169 (R30XMF3) A185 (R30XMA3) H118 (R30XM3)	2-29
HYDRAULIC CONTROL VALVE	
A169 (R30XMF3) A185 (R30XMA3) H118 (R30XM3)	7-12
HYDRAULIC PUMP	
AC HOIST - A185 (R30XMA3) H118 (R30XM3)	7-20
HYDRAULIC PUMP AND MOTOR ASSEMBLY	
AC HOIST - A185 (R30XMA3) H118 (R30XM3)	7-16
HYDRAULIC PUMP ASSEMBLY	
A169 (R30XMF3) A185 (R30XMA3) H118 (R30XM3)	7-24
HYDRAULIC PUMP MOTOR	
AC HOIST - A185 (R30XMA3) H118 (R30XM3)	7-18
HYDRAULIC SUPPLY AND RETURN	
A169 (R30XMF3)	7-2
HOIST OPTION - A185 (R30XMA3), H118 (R30XM3)	7-6
STANDARD - A185 (R30XMA3) H118 (R30XM3)	7-4
HYDRAULIC TANK ASSEMBLY	
A169 (R30XMF3)	7-8
A185 (R30XMA3) H118 (R30XM3)	7-10
L	
LIFT MOTOR	
A169 (R30XMF3) A185 (R30XMA3) H118 (R30XM3)	7-14
LIGHT AND FAN ASSEMBLY	
WITH LED SPOTLIGHT - A169 (R30XMF3) A185 (R30XMA3) H118 (R30XM3)	9-6
LIGHTS AND CONVERTERS	
A169 (R30XMF3) A185 (R30XMA3) H118 (R30XM3)	9-2
LIGHTS AND FAN ASSEMBLY	
A169 (R30XMF3) A185 (R30XMA3) H118 (R30XM3)	9-4
LOAD WHEEL ASSEMBLY	
A185 (R30XMA3) H118 (R30XM3)	6-3
LOAD WHEELS	
A169 (R30XMF3) A185 (R30XMA3)	6-2
M	
MAIN CYLINDER	
THREE STAGE - A185 (R30XMA3) H118 (R30XM3)	8-26
MAIN CYLINDER INSTALLATION	
A185 (R30XMA3) H118 (R30XM3)	8-24

TABLE OF CONTENTS (continued)

DESCRIPTION	PAGE
MAIN LIFT CYLINDER	
THREE STAGE - A169 (R30XMF3)	8-12
MAIN/TRACTION CONTACTOR	
24/36 VOLT - A169 (R30XMF3) A185 (R30XMA3) H118 (R30XM3)	2-30
MAST 3 STAGE	
INNER - A169 (R30XMF3)	8-10
INTERMEDIATE - A169 (R30XMF3)	8-8
OUTER - A169 (R30XMF3)	8-4
MAST CONNECTION	
A169 (R30XMF3) A185 (R30XMA3) H118 (R30XM3)	7-22
MASTER DRIVE UNIT	
DRIVE - H118 (S/N H118N01715L →)	3-25
DRIVE (S/N A169N01537L →) (S/N A185N01571L →)	3-31
HOUSING - H118 (S/N H118N01715L →)	3-24
HOUSING (S/N A169N01537L →) (S/N A185N01571L →)	3-30
OUTPUT - H118 (S/N H118N01715L →)	3-26
OUTPUT (S/N A169N01537L →) (S/N A185N01571L →)	3-32
STEERING PARTS - H118 (S/N H118N01715L →)	3-23
STEERING PARTS (S/N A169N01537L →) (S/N A185N01571L →)	3-29
TRACTION MOTOR DRIVE WHEEL AND CASTER (→ S/N A169N01536L) (→ S/N A185N01570L)	3-2
TRACTION MOTOR, DRIVE WHEEL AND CASTER (→ S/N H118N01714L)	3-4
TURNTABLE BEARING - H118 (S/N H118N01715L →)	3-27
TURNTABLE BEARING (S/N A169N01537L →) (S/N A185N01571L →)	3-33
MASTER DRIVE UNIT ASSEMBLY	
→ S/N A169N01536L → S/N A185N01570L	3-6
→ S/N H118N01714L	3-8
MASTER DRIVE UNIT ASSEMBLY AND ATTACHING PARTS	
S/N A169N01537L → S/N A185N01571L →	3-28
H118 (S/N H118N01715L →)	3-22
MULTI-FUNCTION CONTROL HANDLE	
A169 (R30XMF3) A185 (R30XMA3) H118 (R30XM3)	2-38
MULTI-FUNCTION CONTROL HANDLE ASSEMBLY	
A169 (R30XMF3) A185 (R30XMA3) H118 (R30XM3)	2-36
MULTI-TURN STEER ASSEMBLY	
A169 (R30XMF3) A185 (R30XMA3) H118 (R30XM3)	4-2
O	
OPERATOR PLATFORM	
28 X 40 - AUSTRALIAN MARKET	1-28
28 X 48 - AUSTRALIAN MARKET	1-30
STRUCTURE - A169 (R30XMF3) A185 (R30XMA3)	1-14
STRUCTURE - H118 (R30XM3)	1-18
OUTER, INTERMEDIATE, AND INNER MAST	
THREE STAGE - A185 (R30XMA3) H118 (R30XM3)	8-16
P	
PALLET GRIP	
A169 (R30XMF3) A185 (R30XMA3) H118 (R30XM3)	1-22

TABLE OF CONTENTS (continued)

DESCRIPTION	PAGE
PIVOTING HANDRAIL A169 (R30XMF3) A185 (R30XMA3) H118 (R30XM3)	9-12
R	
RETURN-TO-CENTER STEER ASSEMBLY A169 (R30XMF3) A185 (R30XMA3) H118 (R30XM3)	4-4
FREEZER OPTION - A185 (R30XMA3) H118 (R30XM3)	4-6
S	
STEER MOTOR ASSEMBLY A169 (R30XMF3) A185 (R30XMA3) H118 (R30XM3)	4-8
STEERING KITS	
STRADDLE STABILITY CASTERS A185 (R30XMA3)	9-16
T	
TELEMETRY KITS	10-2
TRACTION HANDLE LARGE CHASSIS - H118 (R30XM3)	2-40
TRACTION MOTOR → S/N A169N01536L → S/N A185N01570L → S/N H118N01714L	3-10
TRACTION MOTOR ASSEMBLY S/N A169N01537L ↔ 5/2015 S/N A185N01571L ↔ 3/2015 S/N H118N01715L ↔ 2/2015	3-12
PAGE 1 OF 6 (2/2015 →)	3-14
PAGE 2 OF 6 (2/2015 →)	3-15
PAGE 3 OF 6 (2/2015 →)	3-16
PAGE 4 OF 6 (2/2015 →)	3-17
PAGE 5 OF 6 (2/2015 →)	3-18
PAGE 6 OF 6 (2/2015 →)	3-19
W	
WIRE DRIVER ASSEMBLY A185, H118	9-20
WIRE GUARD ASSEMBLY A169 (R30XMF3) A185 (R30XMA3) H118 (R30XM3)	9-14
WIRE GUIDANCE A185 (R30XMA3)	2-34
H118 (R30XM3)	2-32
WIRE GUIDANCE KITS	
WIRE HARNESS FURNITURE CHASSIS, PAGE 1 OF 3 - A169 (R30XMF3)	2-70
FURNITURE CHASSIS, PAGE 2 OF 3 - A169 (R30XMF3)	2-72
FURNITURE CHASSIS, PAGE 2 OF 3 - A169 (R30XMF3) ALTERNATE PART	2-74
FURNITURE CHASSIS, PAGE 3 OF 3 - A169 (R30XMF3)	2-76
JUMPER, LH AND RH - AUSTRALIAN MARKET	2-80
LH SIDE GATE SWITCH - AUSTRALIAN MARKET	2-79
RH SIDE GATE SWITCH - AUSTRALIAN MARKET	2-78
WIRE HARNESS CHASSIS PAGE 1 OF 2 - A169 (R30XMF3) A185 (R30XMA3) H118 (R30XM3) (→ 6/2015)	2-56
PAGE 1 OF 2 - A185 (R30XMA3) H118 (R30XM3) (6/2015 →)	2-62

TABLE OF CONTENTS (continued)

DESCRIPTION	PAGE
PAGE 2 OF 2 - A169 (R30XMF3) A185 (R30XMA3) H118 (R30XM3) (→ 6/2015)	2-60
PAGE 2 OF 2 - A185 (R30XMA3) H118 (R30XM3) (6/2015 →)	2-66
WIRE HARNESS LOWER PLATFORM	
A169 (R30XMF3) A185 (R30XMA3) H118 (R30XM3)	2-68
WIRE HARNESS PLATFORM	
ALTERNATE PART - PAGE 1 OF 2	2-48
ALTERNATE PART - PAGE 2 OF 2	2-52
PAGE 1 OF 3 - A169 (R30XMF3) A185 (R30XMA3) H118 (R30XM3)	2-42
PAGE 2 OF 3 - A169 (R30XMF3) A185 (R30XMA3) H118 (R30XM3)	2-44
PAGE 3 OF 3 - A169 (R30XMF3) A185 (R30XMA3) H118 (R30XM3)	2-46

ABBREVIATIONS QUICK REFERENCE SHEET

Listed below are abbreviations used in parts manuals to denote the following expressions:

TERM	DEFINITION	TERM	DEFINITION
Amp	Amperes	FRE	Freezer Environment
AR	As Required	in.	inches
BDI	Battery Discharge Indicators	LPG	Liquefied Petroleum Gas
BWI	Brush Wear Indicator	MAP	Manifold Absolute Pressure
CE	Communicator End	mm	millimeters
CRE	Corrosive Environment	MSTS	Microprocessor Spark Timing System
D/B	Date Break	NPT	National Pipe Threads
dbA	Decibel "A" Scale	O/S	Oversize
DE	Drive End	PTO	Power Take Off
ECH	Empty Container Handler	RPM	Revolutions per Minute
ECH-3	Empty Container Handler - 3 High Stacking	S/N	Serial Number
ECH-4	Empty Container Handler - 4 High Stacking	TMM	Truck Management Module
ECH-5	Empty Container Handler - 5 High Stacking	UL Type D	Diesel-Powered Safety Rating
ECH-6	Empty Container Handler - 6 High Stacking	UL Type DS	Diesel-Powered Safety Rating
ECH-7	Empty Container Handler - 7 High Stacking	UL Type E	Battery-Powered Safety Rating
ECM	Electronic Control Module	UL Type EE	Battery-Powered Safety Rating
ECN	Engineering Change Notice	UL Type ES	Battery-Powered Safety Rating
EEPROM	Electrically Erasable Programmable Read Only Memory	UL Type G	Gasoline-Powered Safety Rating
EPA	US Environmental Protection Agency	UL Type GS	Gasoline-Powered Safety Rating
EPROM	Electrically Programmable Read Only Memory	UL Type LP	Gas-Powered Safety Rating
		UL Type LPS	LP Gas-Powered Safety Rating
		U/S	Undersize
		UL	Underwriters Laboratory
		V	Volts

HOW TO USE THE ILLUSTRATED PARTS MANUAL

This parts manual describes and illustrates assemblies, subassemblies, and detail parts needed for service replacement.

The different constructions are indicated by keys and footnotes. The callouts correspond to descriptions found on the next page.

HYSTER UNIT CODE D001 NORTH AMERICA 06/2001

TABLE OF CONTENTS

DESCRIPTION	PAGE
AIR INTAKE AND FILTER DIESEL (→ D/B 11/98).....	3-22
AIR INTAKE AND FILTER DIESEL (D/B 11/96 →).....	
AIR INTAKE AND FILTER GASOLINE AND LPG.....	
ALTERNATOR GASOLINE, LPG, AND DIESEL.....	
ALTERNATOR TYPES GS, LPS, AND DS.....	
AUXILIARY FUNCTION TUBE TWO AND THREE STAGE FULL F.....	

SECTION 13 NUMERICAL INDEX

PART NO.	PAGE NO.	ITEM NO.	PART NO.	PAGE NO.	ITEM NO.	PART NO.	PAGE NO.	ITEM NO.	PART NO.	PAGE NO.	ITEM NO.
142	3-4	19	10-13	25	11-27	29	12-31	12	16719	3-36	5
12445	3-32	19	10-17	6	11-31	25	16751	3-16	16849	3-34	21
	3-34	1	10-27	11	11-32	37	16849	3-36	16849	3-36	20
			11-11	6	8-4	29	16863	3-28	16863	3-28	17
			11-21	11	8-4	45	16865	3-6	16865	3-6	18
			12	6	9-7	9	16882	4-27	16882	4-27	41
			3	17	9-7	19		9-7		9-7	30
			9	10	9-11	9		9-11		9-11	27
			23	46	9-11	17		10-10		10-10	36
			27	46	10-9	21		10-13		10-13	32
			26	14	10-9	28		11-7		11-7	24
			28	14	10-13	16		11-9		11-9	17
			50	14	11-7	19					

SECTIONS

- 1 FRAME
- 2 ELECTRICAL SYSTEM
- 3
- 4
- 5 BRAKE/ACC
- 6
- 7 MAST-TWO STAG
- 8 MAST-THREE STAG
- 9 MAST-TWO STAG
- 10
- 11

TRANSMISSION HOUSING S/N D001H-2628

KEY:
A: Diesel
B: Gasoline and LPG

ITEM	PART NO.	DESCRIPTION	QTY	
			A	B
		Transmission	1	1
		Case	1	1
1	2021670	Bearing Cap	2	2
2	2023418	Washer	4	4
3	296429	Bolt	4	4
4	293947	Cover	1	1
5	2021390	Coller Pin	2	2
6	1371656	O-Ring	4	4
7	2021329	Plug	1	1
8	2021915	Housing	4	4
9	2021675	Pin	22	22
10	2021336	Bolt	39	39
11	287860	Lockwasher	1	1
12	292682	Hydraulic Pump	1	1
13		Figure 5-3	8	8
14	2021345	Gasket	1	1
15	214364	Bolt	1	1
16	296418	Washer	1	1
17	2021388	Temperature Switch	1	1
18	2021389	Breather	9	9
19	2021383	Dipstick	9	9
20	292515	Bolt	2	2
21	136692	Nut	3	3
22	292527	Bolt	3	2
23	292531	Capscrew	4	4
24	292583	Lockwasher	4	4
25	293637	Bolt	1	1
26	296420	Washer	1	1
	996403	Transmission Kit (Includes Item 7)	1	1
	996405	Transmission Kit (Includes Item 14)	1	1

This Parts Manual is divided into 11 major sections which are listed above. Quick be made by placing the right thumb on the tab of the desired section, bending the pages to the corresponding tab.

© Copy Right Date HYSTER COMPANY See Service Manual for service procedures. 5-15

HOW TO FIND THE DESIRED PART NUMBER

WHEN THE PART NUMBER AND THE NEXT HIGHER ASSEMBLY IS NOT KNOWN:

1. Determine the function and application of the part required. Turn to the Sections Page. Choose the general area of reference most likely to include the part.
2. Turn to the section you chose. Use the Section Table of Contents to determine the assembly which would normally contain the part required. Then locate the part on the assembly breakdown page.

WHEN THE PART NUMBER IS NOT KNOWN AND THE NEXT HIGHER ASSEMBLY IS KNOWN:

3. Determine the assembly the required part is used on. Turn to the Table of Contents (Page i).
4. Locate the assembly the required part is used on and turn to the page indicated for that assembly. Then locate the part on the assembly breakdown page.

WHEN THE PART NUMBER IS KNOWN:

5. Use the Numerical Index (Page 11-1) to find the part number. Turn to the page listed and locate the part as indicated by the item number.

GENERAL:

The assembly breakdowns include part numbers, descriptions, quantities required, keys and footnotes to help in selecting correct parts.

6. Parts Supersession Information. Part numbers that have this history will be displayed in the parts list in the order that they were superseded (from oldest to newest). The superseded part numbers will be shown with a line through them.

Five periods in the PART NO. column (.) indicate that the part is either *Not Serviced Separately* or there is a reference to another figure. A figure reference is denoted by a pointing hand followed by a figure number in the DESCRIPTION column (☞ Figure 10)

7. Keys are used to show two or more similar assemblies, RH and LH assembly parts, etc. Select the appropriate key, "A", "B", "C", "D", or "E" and the corresponding quantity column to find the required parts. Two periods in the QTY column (..) indicate that the part is not used for that assembly.
8. Indented descriptions under the DESCRIPTION column are used to indicate assemblies and

subparts of assemblies. In the example on the previous page, *BEARING CAP* (Item 2) is a subpart of the major assembly *CASE*.

9. Quantities shown are for one assembly. The quantities of the subpart *BEARING CAP* are indicated as two and two. This means two per *CASE* assembly.
10. Serial number breaks identify the most current parts information and are shown as follows:
 - **S/N D001H2628**
Indicates last serial number affected.
 - S/N D001H2629** →
Indicates the first serial number affected.
 - S/N D001H1553** ↔ **S/N D001H3291**
Indicates a range of serial numbers affected.

ECN numbers for pending serial numbers are shown to allow for the inclusion of the most current parts information and are identified as follows:

- **S/N Pending Per ECN 63243**
Indicates a pending serial number for last unit affected.
- S/N Pending Per ECN 63243** →
Indicates a pending serial number for first unit affected.

Date breaks are used to indicate when a change occurred but a subsequent serial number break was not recorded. This is an arbitrary date usually based on the ECN release and are identified as follows:

- **D/B 3/00**
Indicates that a change occurred sometime within that month for the item affected.
- D/B 3/00** →
Indicates that a change occurred sometime within that month for the item affected.
- D/B 3/00** ↔ **D/B 4/00**
Indicates a range of production dates of the item affected.

Contact your local dealer for Hyster lift trucks for serial number information for items with a ECN or a date break.

ORDERING PARTS:

When ordering replacement parts, give the unit serial number, part number, name of part and quantity required.

For any further information on parts, service, or ordering, consult your local dealer for Hyster lift trucks.

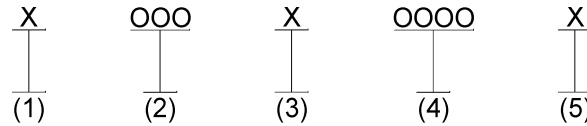
IDENTIFICATION OF TRUCK SERIAL NUMBERS

- (1) and (2) The first letter and three numbers indicate the truck unit code.
- (3) The second letter indicates the plant of manufacture.
- (4) The four or five digit number indicates the production sequence number of the truck.
- (5) The final letter indicates the year of manufacture starting with "A" in 1957, 1980, and 2003.
The letters "I", "O", and "Q" will not be used.

For pending serial numbers contact your local dealer for Hyster lift trucks.

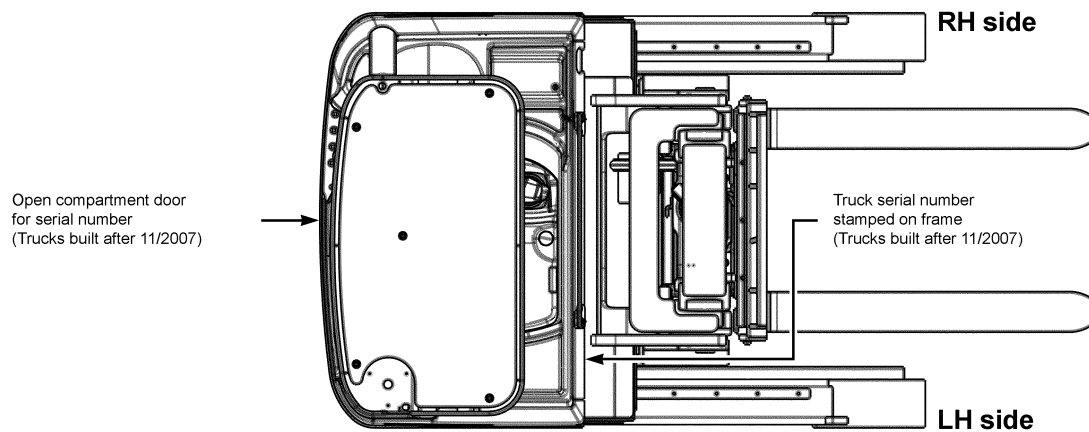

BP990007

Parts referred to in this book as right or left hand parts are in accordance with the illustration above.

IDENTIFICATION OF MAST SERIAL NUMBERS

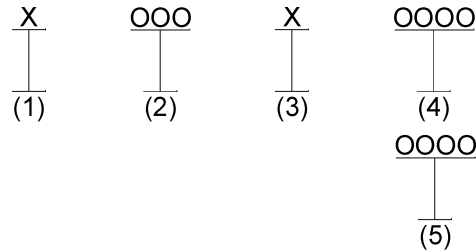

- (1) and (2) The first letter and number indicates the mast unit code.
- (3) The second letter indicates the plant of manufacture.
- (4) The four or five digit number indicates the production sequence number of the mast.
- (5) Carriage travel in millimeters stamped just below the serial number.

Mast Group identification consists of mast unit code (1) and (2) plus carriage travel (5).

For pending production sequence numbers contact your local dealer for Hyster lift trucks.

LIFT EQUIPMENT IDENTIFICATION

1. Fork part number, capacity rating, plant code letter, and date of manufacture are stamped approximately six inches below the top of most forks.
2. The carriage group number is stamped on the right hand side of the top crossmember (pin type) or on the back of the right hand end of the bottom crossmember (hook type). A date code has two letters in line with or below the carriage group number.
3. The mast identification number has a unit code, a letter indicating the plant of manufacture, and a serial number. Underneath the production sequence number is a four digit number that indicates the carriage travel in millimeters.
4. Tilt and lift cylinder group numbers are stamped on the cylinder shell.

Always refer to the group, serial, or part number when ordering service parts.

Modification of masts and carriages by SPED (Special Products Engineering Department) are identified by a model prefix code beginning with the letter "S". contact your dealer for Hyster lift trucks for information on these assemblies.

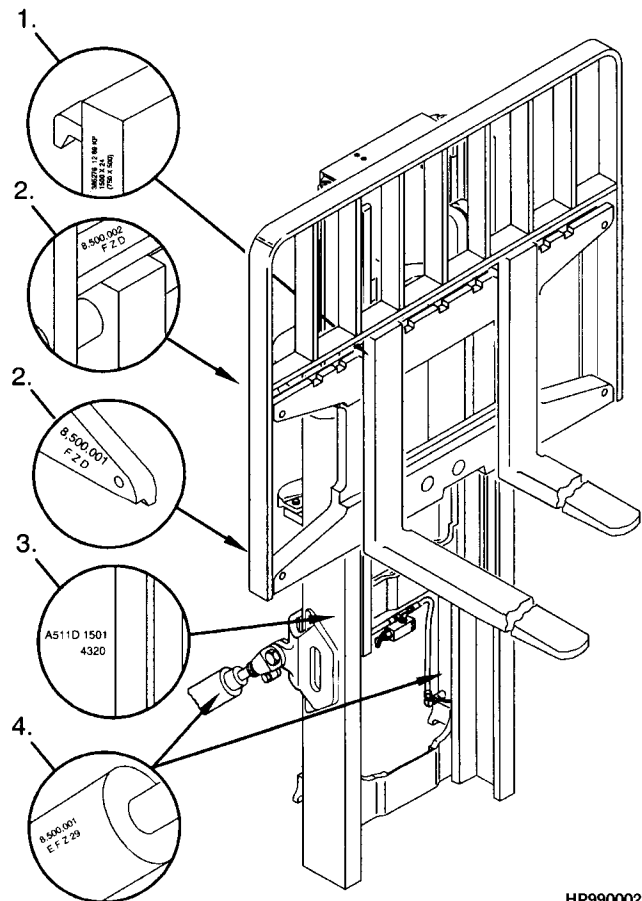

HP990002

IDENTIFICATION OF ATTACHMENT AND SIDE-SHIFT CARRIAGE SERIAL NUMBERS

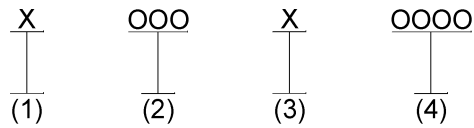

- (1) and (2) The first letter and three numbers indicate the attachment unit code.
- (3) The second letter indicates the plant of manufacture.
- (4) The four or five digit number indicates the production sequence number.
- For pending production sequence numbers contact your local dealer for Hyster lift trucks.

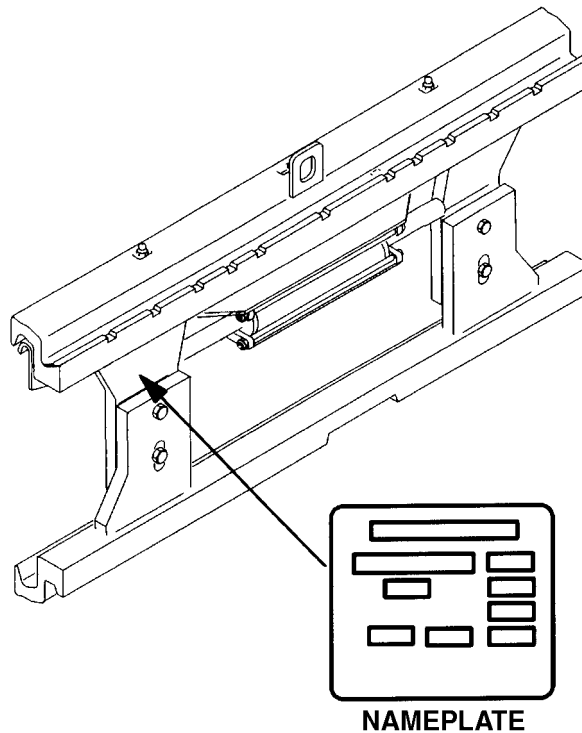

HP990003

Side-shift carriages and attachments have nameplates. Use the serial number found on the nameplate to identify the attachment.

Always refer to the group, serial, or part number when ordering service parts.

Modifications of attachments and side-shift carriages by SPED (Special Products Engineering Department) are identified by a model prefix code beginning with the letter "S". Contact your dealer for Hyster lift trucks for information on these assemblies.

PUBLICATIONS

Every new lift truck is provided with an OPERATING MANUAL. This manual has information that the operator must know for inspection and operation of the lift truck.

SERVICE MAINTENANCE MANUALS, which provide service and overhaul procedures, and PARTS

MANUALS with complete replacement part identification, are available at a nominal fee from your Hyster dealer to assist users in effectively maintaining Hyster lift trucks in a safe, useful condition. See the list below for information on ordering specific publications for this model lift truck.

PUBLICATION	HYSTER PART NUMBER
Operating Manual.....	4031887
Service Manual (Complete).....	4031866
Parts Manual.....	4031888

1

FRAME

SECTION 1
FRAME

DESCRIPTION	PAGE
COVER ASSEMBLY	
CONSOLE - A169 (R30XMF3) A185 (R30XMA3) H118 (R30XM3)	1-24
COWL	
ADJUSTABLE - A169 (R30XMF3) A185 (R30XMA3) H118 (R30XM3)	1-2
FIXED - A169 (R30XMF3) A185 (R30XMA3) H118 (R30XM3)	1-4
DECAL AND PLATE LOCATION	
A169 (R30XMF3)	1-6
A185 (R30XMA3) H118 (R30XM3)	1-8
FORKS	1-26
GATE ASSEMBLY	
AUSTRALIAN MARKET	1-32
HOODS AND COVERS	
A169 (R30XMF3)	1-10
A185 (R30XMA3) H118 (R30XM3)	1-12
OPERATOR PLATFORM	
28 X 40 - AUSTRALIAN MARKET	1-28
28 X 48 - AUSTRALIAN MARKET	1-30
STRUCTURE - A169 (R30XMF3) A185 (R30XMA3)	1-14
STRUCTURE - H118 (R30XM3)	1-18
PALLET GRIP	
A169 (R30XMF3) A185 (R30XMA3) H118 (R30XM3)	1-22

COWL (FIGURE 1-1) ADJUSTABLE — A169 (R30XMF3) A185 (R30XMA3) H118 (R30XM3)

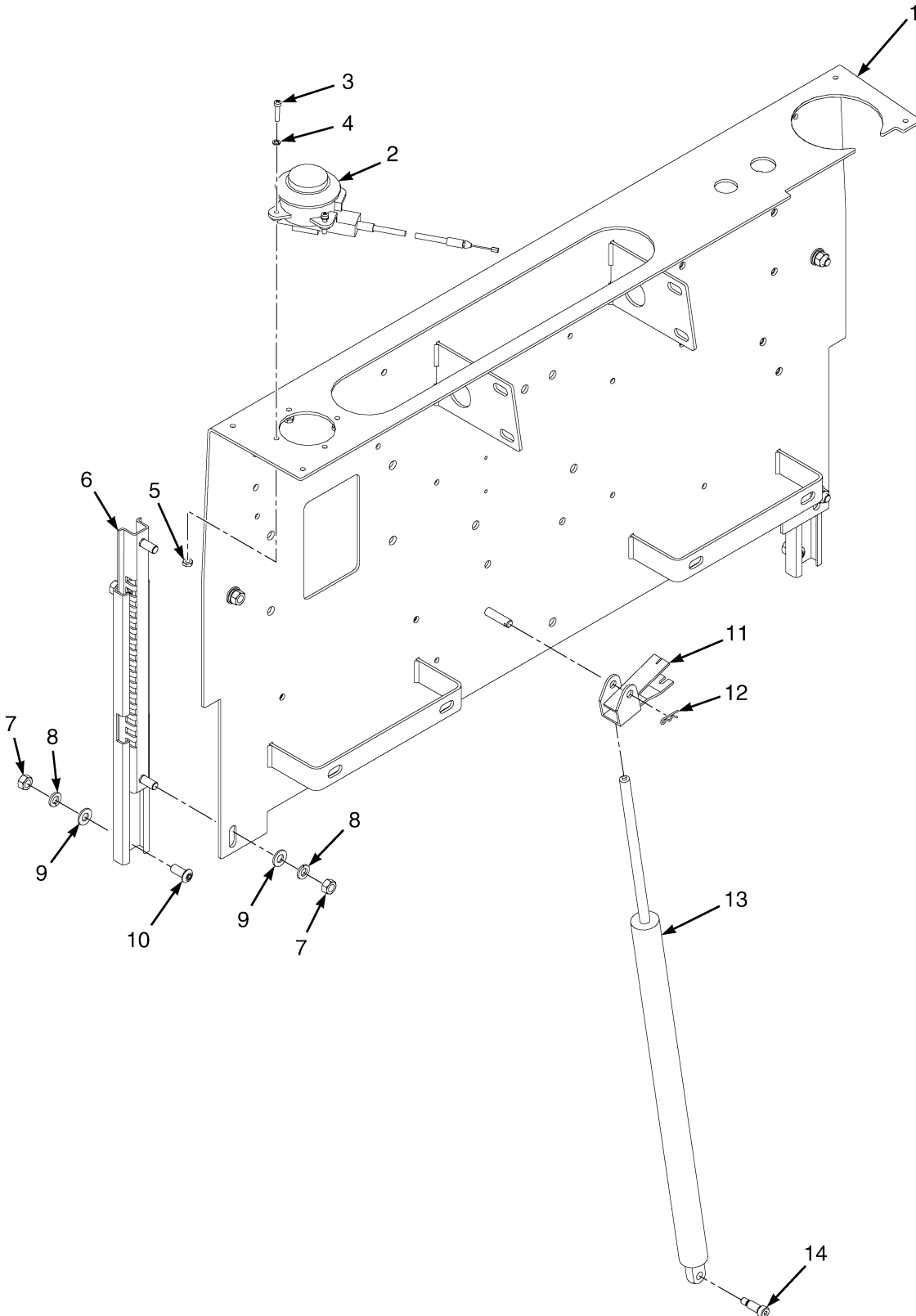

BP120890

COWL
ADJUSTABLE – A169 (R30XMF3) A185 (R30XMA3) H118 (R30XM3)

ITEM	PART NO.	DESCRIPTION	QTY
1	4021559	Cowl	1
2	2036138	Button (Actuator with Cable)	1
3	16850	Screw	4
4	15163	Lockwasher	4
5	15039	Nut	4
6	1535366	Seat Rail (Backrest)	2
7	15055	Nut	8
8	15155	Lockwasher	8
9	18515	Washer	8
10	18728	Capscrew	4
11	2036140	Latch	1
12	18828	Cotter Pin	1
13	2037674	Gas Spring	1
14	1382662	Screw	1